



Thermocouple Thermometers

Ignition Protection Exd



measuring
•
monitoring
•
analysing

TTL-Exd



- Measuring ranges: max. 1100 °C
- NiCr-Ni or Fe-CuNi thermocouples
- Output: sensor type or analogue 4-20 mA
- Thermowells up to 1000, 3000 respectively 5000 mm (depending on model)
- Option: headtransmitter with HART®-protocol or PROFIBUS®/Fieldbus, display
- For ATEX applications, ignition protection Exd

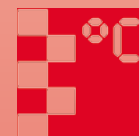

KOBOLD companies worldwide:

ARGENTINA, AUSTRALIA, AUSTRIA, BELGIUM, BULGARIA, CANADA, CHILE, CHINA, COLOMBIA, CZECHIA, EGYPT, FRANCE, GERMANY, GREAT BRITAIN, HUNGARY, INDIA, INDONESIA, ITALY, MALAYSIA, MEXICO, NETHERLANDS, PERU, POLAND, REPUBLIC OF KOREA, ROMANIA, SINGAPORE, SPAIN, SWITZERLAND, TAIWAN, THAILAND, TUNISIA, TURKEY, USA, VIETNAM

KOBOLD Messring GmbH
Nordring 22-24
D-65719 Hofheim/Ts.
Head Office:
+49(0)6192 299-0
+49(0)6192 23398
info.de@kobold.com
www.kobold.com

T2



Description

The KOBOLD thermocouple thermometers comprise a rugged installation fitting made of stainless steel or Inconel with thread, flange or weld-on connection, a connection head out of aluminium casting and a removable measuring element. The measuring insert can be replaced without emptying the installation, since the customised thermowell remains in the installation and seals the process. The instruments are supplied with the ignition protection Exd as a standard and therefore can be installed in relevant hazardous areas.

Thermocouples temperature sensor according to DIN EN60584 part 2, class 1 or 2 is fitted in the measuring insert as standard.

Alternatively these sensors can be designed as single or double thermocouple thermometers.

As an option thermocouples thermometers can be supplied with a head transmitter. Transmitter with a standard 4-20 mA signal, with HART® protocol or with PROFIBUS®/Fieldbus are there to choose from.

Beside the available thermocouples thermometers according to DIN-standard, there are customised versions relating to the immersion length, the connection head, the materials, the process connection or the tolerance classes deliverable on request.

Head Transmitter

Thermocouples with head transmitter are used to transmit measuring signals noise-free over long distances.

The head transmitter which is encapsulated in epoxide resin is located right in the connection head and delivers a temperature-linear output signal of 4-20 mA. The head transmitter is available with standardised communication systems just like HART® protocol or PROFIBUS®/Fieldbus.

Applications

The thermocouple thermometers with thread-, flange- or weld-on connection are favourably used for the temperature measurement in liquids, solids and gaseous media. The reliable watertightness of these installation methods for gauge pressure and vacuum is an important criteria for selection.

Application areas are located in the air-conditioning and cooling industry, the heating-, furnace-, mechanical- and apparatus-construction as well as in the complete industry.

For all applications in hazardous areas, the instruments are supplied with the ignition protection Exd.

Technical Data

Measuring range:	1.4404, max. 750°C, others, max. 1100°C
Sensor:	single or double-sensor
Accuracy:	class 1 or class 2
Ambient temperature:	-40 ... +150°C with ceramic terminal base (without transmitter) -40 ... +85°C (with transmitter) -20 ... +70°C (with LCD display) -20 ... +80°C (with LED display)
Operating pressure:	up to 250 bar (depending on thermowell)
Connection head:	form XD with chain
Cable entry:	M 20x 1.5 standard (others on request)
Materials:	
- Sensor:	stainless steel 1.4404 (Type J) Alloy 600 (Type K)
- Thermowell:	stainless steel 1.4404 (others on request)
- Neckpipe:	stainless steel 1.4404
- Connection head:	aluminium, painted
- Terminal base:	ceramic (without transmitter)
Process connection:	
- Thread:	G ½ male, G ¾ male, G 1 male, ½" NPT, ¾" NPT, 1" NPT
- DIN-flange:	DN 15, 20, 25, 32, 40, 50
- ANSI-flange:	½", ¾", 1", 1½", 2"
- Weld-in:	¾", 1", 1¼"
Sensor wiring:	2-wire
Protection:	connection head IP 54 ... 68 depending on cable gland and sealing sensor IP 68
ATEX-approval:	⊕ II 2 GD Ex d IIC T6
Head transmitter:	
- Output:	analogue output 4-20 mA
- Communication:	HART®-protocol, PROFIBUS®/Fieldbus
- Minimum meas. span:	standard transmitter 25 K transmitter with HART® 10 K transmitter with Profibus®/ Fieldbus 5 K
- Supply voltage:	8-35 V _{DC} for standard transmitter and transmitter with HART® 9-32 V _{DC} for transmitter with Profibus®/Fieldbus
Display:	
- Type:	4 digit LCD or LED
- Supply:	loop powered
- Voltage drop out:	LCD max. 2.5 V LED 3.3 V at 4 mA 3.7 V at 20 mA



Order Details (example: **TTL-1 1 2 L N D N 5 C A 1**)

Model	Sensor specification				
	Type	Sensor type	Sensor wiring	Connection head/ transmitter	Process connection of sensor
TTL-	0 = without		0 = without	0 = without (for TTL-0/3)	
	1 = standard 2 = with nipple union X = special	1 = 1 x type J, cl. 2; 1.4404 2 = 2 x type J, cl. 2; 1.4404 3 = 1 x type K, cl.2; Alloy 600 4 = 2 x type K, cl.2; Alloy 600 5 = 1 x type J, cl. 1; 1.4404 6 = 2 x type J, cl. 1; 1.4404 7 = 1 x type K, cl.1; Alloy 600 8 = 2 x type K, cl.1; Alloy 600 X = special	2 = 2-wire	L = ATEX Exd / without transmitter A = ATEX Exd/programmable 2-wire transmitter (model: 5334D) B = ATEX Exd/ 2-wire transmitter with HART® protocol (model: 5337D) C = ATEX Exd/transmitter with PROFIBUS®/Fieldbus (model: 5350A) X = special option (specify in clear text)	N ¹⁾ = ½" NPT male G = G ½ male X = special
	3 = measuring insert				0 = without

¹⁾ choose "N" for TTL-2



Order Details (continued)

Thermowell specification				Length (sensor, thermowell, measuring insert) ³⁾ (see drawings)	Options
Thermowell type	Process connection	Process connection size	Nominal pressure (process connection)		
0 = without B = cylindrical, multipart, welded G = cylindrical, bar stock/drilled with stepped shank D = tapered shank, bar stock/drilled X = special option	0 = without (for TTL-3)	0 = without (for TTL-3)	0 = without (for TTL-3)	only for TTL-0 (only thermowell) 0 = without lagging ext. "T" 1 = with lagging ext. "T" sensor with thermowells (only for TTL-1/TTL-2) A = with standard neckpipe "HL"/ without lagging ext. "T" B = with standard neckpipe "HL"/ with lagging extension "T" C ⁴⁾ = without neckpipe "HL"/ with lagging extension "T" D ⁴⁾ = without neckpipe "HL"/ without lagging ext. "T" E = with special neckpipe length "HL"/ with lagging ext. "T" F = with special neckpipe length "HL"/ without lagging exten- sion "T" sensor without thermowells (only for TTL-1/TTL-2) G = with standard neckpipe length "HL" H = with special neckpipe length "HL" J = without neckpipe "HL" X = special option (specify in clear text)	0 = without 1 = with LCD display 2 ⁵⁾ = with LED display Y = special option (specify in clear text)
	G = G-thread N = NPT-thread	4 = 1/2" 5 = 3/4" 6 = 1" X = special	A = PN 25 (only for thermowell B) B = PN 100 (only for thermowell G) C = PN 250 (only for thermowell D)		
	S ²⁾ = welded	5 = 3/4" 6 = 1" 7 = 1 1/4" X = special	B = PN 100 (only for thermowell G) C = PN 250 (only for thermowell D)		
	F = DIN flange	4 = DN15 5 = DN20 6 = DN25 7 = DN32 8 = DN40 9 = DN50 X = special	1 = PN6 2 = PN16 3 = PN40 4 = PN100 (not for DN 15) X = special		
	A = ANSI flange	4 = 1/2" 5 = 3/4" 6 = 1" 8 = 1 1/2" 9 = 2" X = special	5 = 150 lbs 6 = 300 lbs 7 = 600 lbs (not for 1/2") 8 = 900 lbs (not for 1/2") 9 = 1500 lbs (not for 1/2") X = special		

²⁾ not for thermowell type B

³⁾ immersion length "U" and hole diameter "I" (when ordering a/with thermowell) or "EL" (when ordering without thermowell), neckpipe length "HL" (when different from standard. i.e. for TTL-1 standard. is 130 mm, for TTL-2 standard is 150 mm), lagging extension "T" (if ordered) and measuring insert length "ML" (when ordering TTL-3) must be specified in clear text when ordering.
Please check lengths very precisely in order to ensure a perfect match between sensor and thermowell.

⁴⁾ not for TTL-2

⁵⁾ display only available for 4...20 mA or HART[®] transmitters

Note: Nominal pressure for TTL-3 and sensors without thermowell is atmospheric pressure.



Order Details for Ordering only the Thermowell (example: **TWL-0 0 0 0 N B G 4 0 0 0**)

Model	Sensor type	Sensor type/class	Sensor Wiring	Connection head/ transmitter	Process connection of temperature sensor ¹⁾
TWL-	0 = without	0 = without	0 = without	0 = without	N ¹⁾ = ½" NPT male G = G½ male X = special

¹⁾ choose N for nipple and union version

Order Details for Ordering only the Thermowell (continued)

Thermowell specification				Immersion length and lagging extension length ¹⁾	Special option
Thermowell type	Process connection	Process connection size	Nominal pressure (process connection)		
Please use the specification codes according to order table shown on page 4				0 = without lagging extension 1 = with lagging extension	0 = without Y = option acc. specification

¹⁾ Immersion length "U", hole diameter "i" and lagging extension "T" must be specified in writing.
Please check lengths very precise in order to ensure a perfect match of sensor and thermowell.

Technical data special materials

(others on request)

Alloy 600 (Material no. 2.4816)	Max. temperature 1090°C. Excellent corrosion resistance against oxidation up to 980°C, to carburization and to stress corrosion cracking at elevated temperatures.
Alloy 601 (Material no. 2.4851)	Max. temperature 850°C. Excellent resistance against oxidation, against carburization and good mechanical properties.
Alloy 625 (Material no. 2.4856)	Max. temperature 815°C. Excellent corrosion resistance against oxidation of sulphuric, nitric, phosphoric, hydrochloric acid and alkalis. It is widely used in a variety of high temperature aerospace, chemical process industry, and power industry applications. It provides excellent service in short term applications at temperatures up to approximately 815 °C long-term elevated temperature service, use of alloy 625 is best restricted to a maximum of 595 °C.
Alloy 800 (Material no. 1.4876)	Max. temperature 870°C. Good resistance to oxidizing agents, fuels nitriding and maintaining good mechanical properties from cryogenic to high temperature environments for high temperatures should go to 800H.
Alloy 800H (Material no. 1.4958)	Max. temperature 1100°C. basic composition as alloy 800 but with higher creep and rupture.
Alloy 800HT (Material no. 1.4959)	Max. temperature 1100°C. High creep and stress rupture resistance above 700°C. It is used specially at temperatures above 800°C.
Alloy DS (Material no. 1.4862)	Max. temperature 1100°C. High creep and stress rupture resistance above 700°C. It is specially used at temperatures above 800°C.
1.4845 (AISI 310 S) (Material no. 1.4845)	Max. temperature 1150°C. Excellent high temperature properties with good ductility and weldability. It resists oxidation in continuous service at temperatures up to 1150 °C. Excellent resistance at normal temperatures, and when in high temperature service exhibits good resistance to oxidizing and carburizing atmospheres. Resists fuming nitric acid at room temperature and fused nitrates up to 425 °C. Good resistance to oxidation in intermittent service in air at temperatures up to 1040 °C and 1150 °C in continuous service. Good resistance to continuous heat at 1150 °C. Good resistance to thermal fatigue and cyclic heating. Widely used where sulphur dioxide gas is encountered at elevated temperatures. Continuous use in 425...860 °C range not recommended due to carbide precipitation.
Alloy 200 (Material no. 2.4066)	Max. temperature 300°C. Excellent corrosion resistance against many corrosive media (specially to caustic alkalis, halides and a large number of organic compounds).
Alloy 201 (Material no. 2.4068)	Max. temperature 600°C. Equal Alloy 200 but with a very low carbon content.

Dimensions Temperature Sensor TTL-1

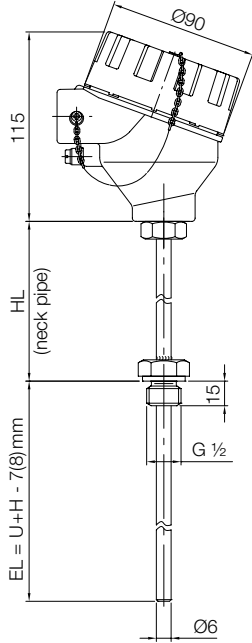

HL = neckpipe length
 standard 130 mm for TWL-1
 standard 150 mm for TWL-2
EL = immersion length
EL = U+H-7 mm for thermowell type B
 U+H-8 mm for thermowell type G/D

Dimensions Temperature Sensor TTL-2

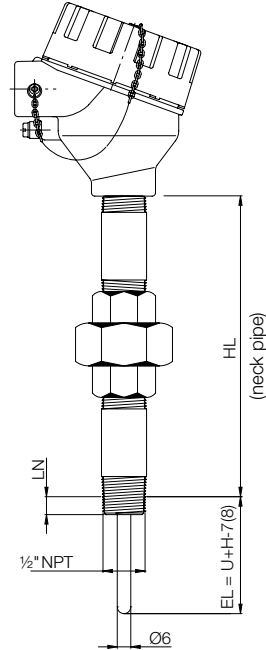

U = immersion length thermowell
 (see drawing thermowell)
H = length see thermowell
LN = screw-in-length by hand
 (approx. 8.1 mm at 1/2" NPT)

Dimensions Measuring Insert TTL-3

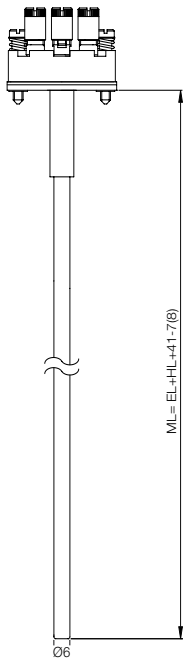

HL = neckpipe length
EL = immersion length
ML = measuring insert length

Dimensions Connection Head with Display

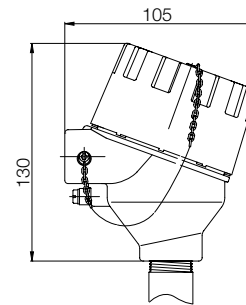

Lagging Extension "T"

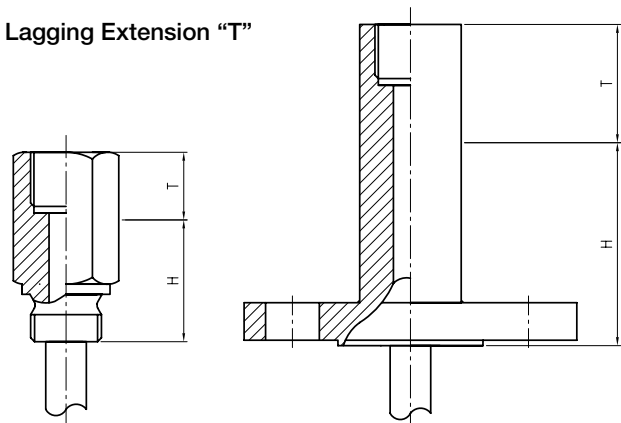

Dimensions Thermowell Model TWL-...B...

Nominal pressure: max. PN25 at 20°C,
Cylindrical thermowell, welded, with process connection G-thread

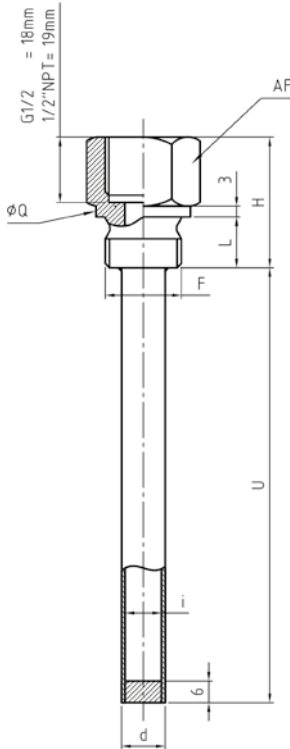

Process connection	Max. total length	AF	F	i	d	H	L	Q
G-thread	5000 mm	27	G 1/2 B	10	12	36	14	26
				12	14			
		36	G 3/4 B	10	12	38	16	31.7
				2	14			
		41	G 1 B	10	12	40	18	39
				12	14			

Nominal pressure: max. PN25 at 20°C
Cylindrical thermowell, welded, with process connection NPT-thread

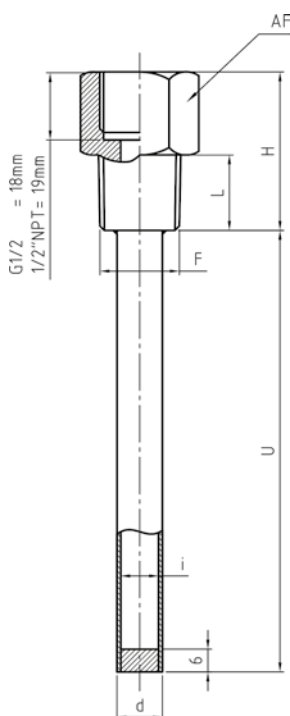

Process connection	Max. total length	AF	F	i	d	H	L
NPT-thread	5000 mm	27	1/2 NPT	10	12	42	20
				12	14		
		27	3/4 NPT	10	12	43	24
				12	14		
		36	1 NPT	10	12	46	24
				12	14		

Nominal pressure: max. PN6...40 at 20°C,
Cylindrical thermowell, welded, with process connection flange acc. to DIN or ANSI

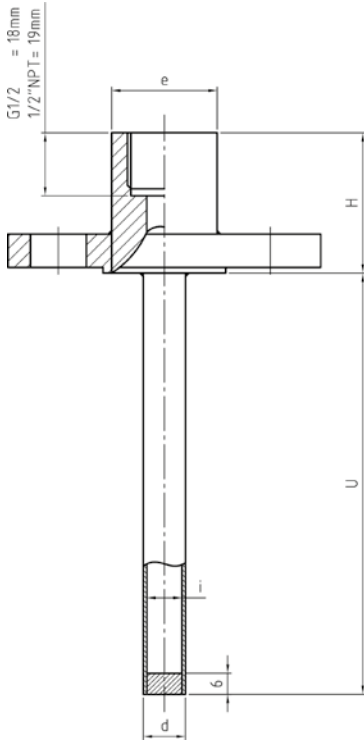

Process connection		Max. total length	i	d	H	e
with flange	ANSI 1/2"	5000 mm	10/12	12/14	40	30
	ANSI 3/4"					
	ANSI 1"					
	ANSI 1 1/2"					
	ANSI 2"					35
	DIN DN 15	10/12	12/14	40	30	
	DIN DN 20					
	DIN DN 25					
	DIN DN 32					
	DIN DN 40					
DIN DN 50	35					

Dimensions Thermowell Model TWL-...G...

Nominal pressure: max. PN100 at 20°C,
Cylindrical thermowell out of solid material with stepped shaft and process connection G-thread

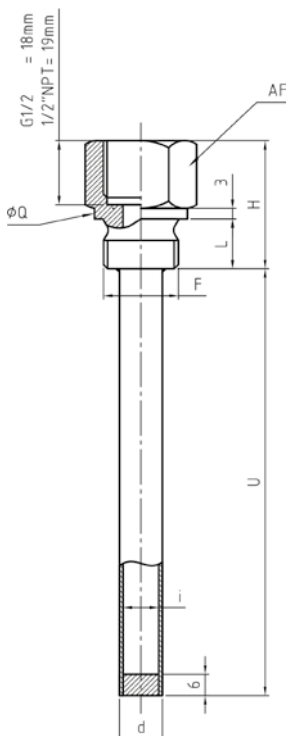

Process connection	Max. total length	SW	F	i	d	D	H	L	Q
G-thread	1000 mm	27	G 1/2 B	7-8-9	15	17.5	46	14	26
				10-12	17.5	17.5			
		36	G 3/4 B	7-8-9	15	18		16	31.7
				10-12	18	21			
		41	G 1 B	7-8-9	15	21	18	39	
				10-12	18	25			51

Nominal pressure: max. PN100 at 20°C,
Cylindrical thermowell out of solid material with stepped shaft and process connection NPT-thread

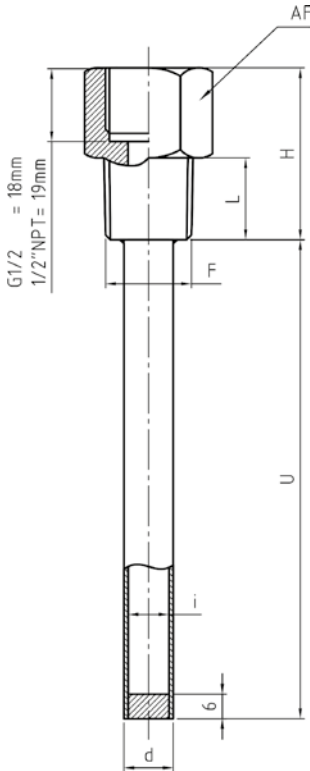

Process connection	Max. total length	AF	F	i	d	D	H	L
NPT-thread	1000 mm	27	½" NPT	7-8-9	15	17.5	46	20
				10-12	17.5	17.5		
		27	¾" NPT	7-8-9	15	18		
				10-12	18	21		
		36	1" NPT	7-8-9	15	21	51	24
				10-12	18	25		

Nominal pressure: as flange rating (max. PN100 at 20°C),
Cylindrical thermowell out of solid material with stepped shaft and process connection flanges acc. to DIN or ANSI

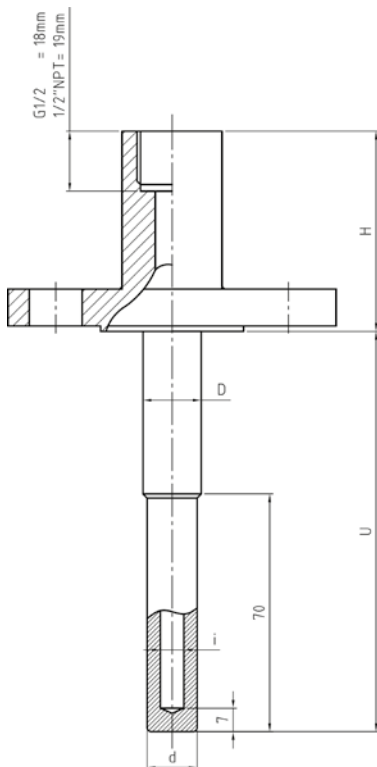

Process connection	Max. total length	i	d	D	H	e
flange	1000 mm	7-8-9	15	17.5	60	30
		7-8-9	15	18		
		7-8-9	15	21		
		7-8-9	15	17.5	60	30
		7-8-9	15	18		
		7-8-9	15	21		
		7-8-9	15	21	60	35
7-8-9	15	21				
			10-12	18		
7-8-9	15	21				
			10-12	18		

Nominal pressure: PN100 at 20°C,

Cylindrical thermowell out of solid material with stepped shaft and process connection for weld-on

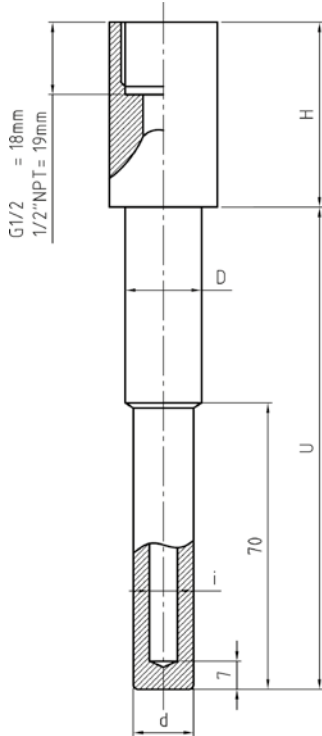

Process connection		Max. total length	F	i	d	D	H
for weld-on	DN 3/4"	1000 mm	26.9	7-8-9	15	19	46
				10-12	18		
	DN 1"		33.4	7-8-9	15	22	51
				10-12	18		

Dimensions Thermowell Model TWL-...D...

Nominal pressure: PN250 at 20°C,

Conical thermowell out of solid material with process connection G-thread

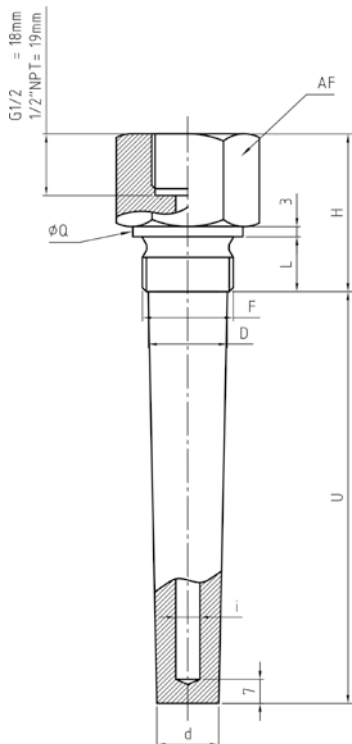

Process connection	Max. total length	AF	F	i	d	D	H	L	Q
G-thread	1000 mm	36	G 3/8 B	7-8-9	18	23	46	20	31.7
				10-12	21				
		41	G 1 B	7-8-9	18	29	51	25	39
				10-12	21				

Nominal pressure: PN250 at 20°C,
Conical thermowell out of solid material with process connection NPT-thread

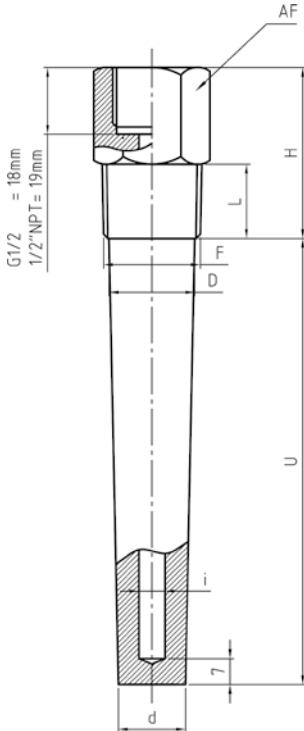

Process connection	Max. total length	AF	F	i	d	D	H	L
NPT-thread	1000 mm	27	3/4" NPT	7-8-9	18	23	46	20
				10-12	21			
		36	1" NPT	7-8-9	18	29	51	24
				10-12	21			

Nominal pressure: as flange rating (max. PN250 at 20°C)
Conical thermowell out of solid material with process connection flange acc. to DIN or ANSI

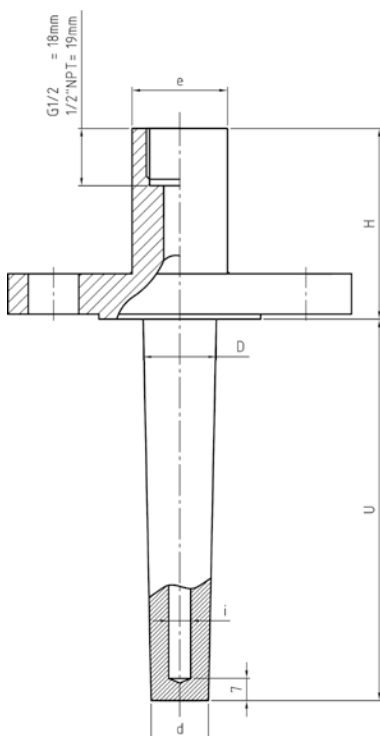

Process connection		Max. total length	i	d	D	H	e
flange	ANSI 1"	1000 mm	7-8-9	18	23	60	30
			10-12	21			
	ANSI 1 1/2"		7-8-9	18	29		35
			10-12	21			
	ANSI 2"		7-8-9	18	23	60	30
			10-12	21			
	DIN DN 25		7-8-9	18	29		35
			10-12	21			
	DIN DN 32		7-8-9	18	23	60	30
			10-12	21			
	DIN DN 40		7-8-9	18	29		35
			10-12	21			
	DIN DN 50		7-8-9	18	23	30	
			10-12	21			

Nominal pressure: PN250 at 20°C,

Conical thermowell out of solid material with process connection flange acc. to DIN or ANSI

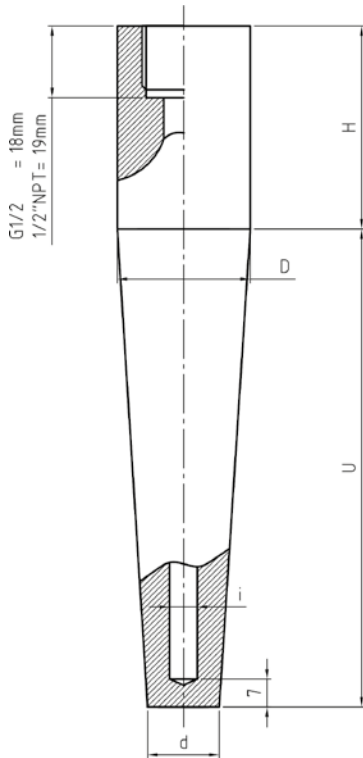

Process connection		Max. total length	i	d	D	H
for weld-on	DN 1"	1000 mm	7-8-9	18	33.4	51
			10-12	21		
	DN 1¼"		7-8-9	18	38.1	51
			10-12	21		



Thermocouple Thermometers

Ignition Protection Exia



measuring
•
monitoring
•
analysing

TTL-Exia



- Measuring ranges: max. 1100 °C
- NiCr-Ni or Fe-CuNi thermocouples
- Output: sensor or analogue 4-20 mA
- Thermowells up to 1000, 3000 respectively 5000 mm (depending on model)
- Option: headtransmitter with HART® protocol or PROFIBUS®/Fieldbus
- For ATEX applications, ignition protection Exia



T2

KOBOLD companies worldwide:

ARGENTINA, AUSTRALIA, AUSTRIA, BELGIUM, BULGARIA, CANADA, CHILE, CHINA, COLOMBIA, CZECHIA, EGYPT, FRANCE, GERMANY, GREAT BRITAIN, HUNGARY, INDIA, INDONESIA, ITALY, MALAYSIA, MEXICO, NETHERLANDS, PERU, POLAND, REPUBLIC OF KOREA, ROMANIA, SINGAPORE, SPAIN, SWITZERLAND, TAIWAN, THAILAND, TUNISIA, TURKEY, USA, VIETNAM

KOBOLD Messring GmbH
Nordring 22-24
D-65719 Hofheim/Ts.
Head Office:
+49(0)6192 299-0
+49(0)6192 23398
info.de@kobold.com
www.kobold.com



Description

The KOBOLD thermocouple thermometers comprise a rugged installation fitting made of stainless steel or Inconel with thread, flange or weld-on connection, a connection head out of aluminium casting and a removable measuring element. The measuring insert can be replaced without emptying the installation, since the customised thermowell remains in the installation and seals the process. The instruments are supplied with the ignition protection Exia as a standard and therefore can be installed in relevant hazardous areas.

Thermocouples temperature sensor according to DIN EN 60584 part 2, class 1 or 2 are fitted in the measuring insert as standard.

Alternatively these sensors can be designed as single or double thermocouple thermometers.

As an option the thermocouples thermometers can be supplied with a head transmitter. Transmitters with a standard 4-20 mA signal, with HART® protocol or with PROFIBUS®/Fieldbus are there to choose from.

Beside the available thermocouples thermometers according to DIN-standard, there are customised versions relating to the immersion length, the connection head, the materials, the process connection or the tolerance classes deliverable on request.

Head Transmitter

Thermocouples with head transmitter are used to transmit measuring signals noise-free over long distances.

The head transmitter which is encapsulated in epoxide resin is located right in the connection head and delivers a temperature-linear output signal of 4-20 mA. The head transmitter is available with standardised communication systems just like HART® protocol or PROFIBUS®/Fieldbus.

Applications

The thermocouple thermometers with thread-, flange- or weld-on connection are favourably used for the temperature measurement in liquids, solids and gaseous media. The reliable watertightness of these installation methods for gauge pressure and vacuum is an important criteria for selection.

Application areas are located in the air-conditioning and cooling industry, the heating-, furnace-, mechanical- and apparatus-construction as well as in the complete industry.

For all applications in hazardous areas, the instruments are supplied with the ignition protection Exia.

Technical Data

Measuring range:	1.4404, max. 750 °C, others, max. 1100 °C
Sensor:	single or double-sensor
Accuracy:	class 1 or class 2
Ambient temperature:	-40 ... +150 °C with ceramic terminal base (without transmitter) -40 ... +85 °C (with transmitter)
Operating pressure:	depending on TTL version
Connection head:	form B with chain
Cable entry:	M 20x1.5 standard (others on request)
Materials:	
Sensor:	stainless steel 1.4404 (Type J) Alloy 600 (Type K)
Protective tube:	1.4404 (others on request)
Neckpipe:	stainless steel 1.4404
Connection head:	aluminium, painted
Terminal base:	ceramic (without transmitter)
Process connection:	
Thread:	G 1/2 male, G 3/4 male, G1 male, 1/2" NPT, 3/4" NPT, 1" NPT
DIN flange:	DN 15, 20, 25, 32, 40, 50
ANSI flange:	1/2", 3/4", 1", 1 1/2", 2"
Weld-in	3/4", 1", 1 1/4"
Sensor wiring:	2-wire
Protection:	connection head IP65 sensor IP68
ATEX-approval:	Ex II 1 GD Ex ia IIC T4...T6 Ex iaD 20 IP65 T85 °C 20 °C ≤ Ta ≤ +60 °C
Head transmitter:	
Output:	analogue output 4-20 mA
Communication:	HART® protocol, Profibus®/Fieldbus



Screw-in thermocouple form 2G with or without neckpipe, protection Exia, protective tube G 1/2 male according to DIN 43772 (with neckpipe), p_{max} 10 bar, with removable measuring element

Model	Immersion length [mm]	Process connection	Sensor type/ category	Wiring	Connection head	Head transmitter	Options
TTL-L94 (without neckpipe)	10 = 100 Ø 8x6 16 = 160 Ø 8x6 25 = 250 Ø 8x6	2 = G 1/2	1 = 1x type J, cl 2; 1.4404 2 = 2x type J, cl 2; 1.4404 3 = 1x type K, cl 2; Alloy 600 4 = 2x type K, cl 2; Alloy 600 5 = 1x type J, cl 1; 1.4404 6 = 2x type J, cl 1; 1.4404 7 = 1x type K, cl 1; Alloy 600 8 = 2x type K, cl 1; Alloy 600 X²⁾ = special	2 = 2-wire	G = form B, with chain Y = special connection head (to be specified in writing)	0 = without A³⁾ = programmable transmitter 2-wire (5334D) B³⁾ = transmitter with HART® protocol 2-wire (5337D) C³⁾ = transmitter PROFIBUS®/ Fieldbus (5350B)	0 = without Y = acc. description
TTL-B94 (with neckpipe)	40 = 400 Ø 8x6 XX¹⁾ = special length Ø 8x6						

¹⁾ Please specify special length in writing

²⁾ Please specify special type in writing

³⁾ Please specify measuring range in writing

Screw-in thermocouple form 2G with neckpipe, protection Exia, protective tube G 1 male according to DIN 43772, p_{max} 10 bar, with removable measuring element

Model	Immersion length [mm]	Process connection	Sensor type/ category	Wiring	Connection head	Head transmitter	Options
TTL-CB4	10 = 100 Ø10x8 16 = 160 Ø10x8 25 = 250 Ø10x8 40 = 400 Ø10x8 XX¹⁾ = special length	4 = G 1	1 = 1x type J, cl 2; 1.4404 2 = 2x type J, cl 2; 1.4404 3 = 1x type K, cl 2; Alloy 600 4 = 2x type K, cl 2; Alloy 600 5 = 1x type J, cl 1; 1.4404 6 = 2x type J, cl 1; 1.4404 7 = 1x type K, cl 1; Alloy 600 8 = 2x type K, cl 1; Alloy 600 X²⁾ = special	2 = 2-wire	G = form B, with chain Y = special connection head (to be specified in writing)	0 = without A³⁾ = programmable transmitter 2-wire (5334D) B³⁾ = transmitter with HART® protocol 2-wire (5337D) C³⁾ = transmitter PROFIBUS®/ Fieldbus (5350B)	0 = without Y = acc. description

¹⁾ Please specify special length in writing

²⁾ Please specify special type in writing

³⁾ Please specify measuring range in writing



Screw-in thermocouple thermometer form 3G with neckpipe, protection Exia, protective tube G 1 male according to DIN 43772 for faster response time, p_{max} 30 bar, with removable measuring element

Model	Immersion length [mm]	Process connection	Sensor type/ category	Wiring	Connection head	Head transmitter	Options
TTL-G94	16 = 160 \varnothing 8x6 25 = 250 \varnothing 8x6 28 = 280 \varnothing 8x6 XX¹⁾ = special length \varnothing 8x6	4 = G 1	1 = 1x type J, cl 2; 1.4404 2 = 2x type J, cl 2; 1.4404 3 = 1x type K, cl 2; Alloy 600 4 = 2x type K, cl 2; Alloy 600 5 = 1x type J, cl 1; 1.4404 6 = 2x type J, cl 1; 1.4404 7 = 1x type K, cl 1; Alloy 600 8 = 2x type K, cl 1; Alloy 600 X²⁾ = special	2 = 2-wire	G = form B, with chain Y = special connection head (to be specified in writing)	0 = without A³⁾ = programmable transmitter 2-wire (5334D) B³⁾ = transmitter with HART [®] protocol 2-wire (5337D) C³⁾ = transmitter PROFIBUS [®] /Fieldbus (5350B)	0 = without Y = acc. description

¹⁾ Please specify special length in writing

²⁾ Please specify special type in writing

³⁾ Please specify measuring range in writing

Inmersion thermocouple thermometer form 1, protection Exia, protective tube according to DIN 43772 with adjustable flange, p_{max} 10 bar, with removable measuring element

Model	Immersion length [mm]	Process connection	Sensor type/ category	Wiring	Connection head	Head transmitter	Options
TTL-1F4	50 = 500 \varnothing 15 71 = 710 \varnothing 15 1T = 1000 \varnothing 15 T4 = 1400 \varnothing 15 2T = 2000 \varnothing 15 XX¹⁾ = special length \varnothing 15	B = adjustable G $\frac{3}{4}$ male st. st. C = aluminium sliding flange DIN43743	1 = 1x type J, cl 2; 1.4404 2 = 2x type J, cl 2; 1.4404 3 = 1x type K, cl 2; Alloy 600 4 = 2x type K, cl 2; Alloy 600 5 = 1x type J, cl 1; 1.4404 6 = 2x type J, cl 1; 1.4404 7 = 1x type K, cl 1; Alloy 600 8 = 2x type K, cl 1; Alloy 600 X²⁾ = special	2 = 2-wire	G = form B, with chain Y = special connection head (to be specified in writing)	0 = without A³⁾ = programmable transmitter 2-wire (5334D) B³⁾ = transmitter with HART [®] protocol 2-wire (5337D) C³⁾ = transmitter PROFIBUS [®] /Fieldbus (5350B)	0 = without Y = acc. description

¹⁾ Please specify special length in writing

²⁾ Please specify special type in writing

³⁾ Please specify measuring range in writing



Weld-on thermocouple form 4, protection Exia, protective tube according to DIN 43772, p_{max} 250 bar

Model	Immersion length [mm]	Process connection	Sensor type/ category	Wiring	Connection head	Head transmitter	Options
TTL-D	1406 = 65/140 (D1) st.st 1.4404	0 = weld-on	1 = 1x type J, cl 2; 1.4404	2 = 2-wire	G = form B, with chain X = special connec- tion head (to be specified in writing)	0 = without A ⁴⁾ = programmable transmitter 2-wire (5334D) B ⁴⁾ = transmitter with HART [®] protocol 2-wire (5337D) C ⁴⁾ = transmitter PROFIBUS [®] / Fieldbus (5350B)	0 = without Y = acc. description
	2412 = 125/200 (D2) st.st 1.4404		2 = 2x type J, cl 2; 1.4404				
	4406 = 65/200 (D2) st.st 1.4404		3 = 1x type K, cl 2; Alloy 600				
	5412 = 125/260 (D2) st.st. 1.4404		4 = 2x type K, cl 2; Alloy 600				
	XXXX ¹⁾ = special length		5 = 1x type J, cl 1; 1.4404				
	1906 ²⁾ = 65/140 (D1) st.st 1.4903		6 = 2x type J, cl 1; 1.4404				
	2912 ²⁾ = 125/200 (D2) st.st 1.4903		7 = 1x type K, cl 1; Alloy 600				
	4906 ²⁾ = 65/200(D2) st.st 1.4903		8 = 2x type K, cl 1; Alloy 600				
	5912 ²⁾ = 125/260 (D5) st.st. 1.4903		X ³⁾ = special				
	XXXX ¹⁾ = special length						

¹⁾ Please specify special length in writing ²⁾ Stainless steel 1.7380 or 1.7337 on request ³⁾ Please specify special type in writing
⁴⁾ Please specify measuring range in writing

Insertion thermocouple thermometer form 3F flange DN25 PN40, protection Exia, protective tube according to DIN 43772 for faster response time, p_{max} 30 bar, with removable measuring element

Model	Immersion length [mm]	Process connection	Sensor type/ category	Wiring	Connection head	Head transmitter	Options
TTL-F94	22 = 225	4 = flange DN25	1 = 1x type J, cl 2; 1.4404	2 = 2-wire	G = form B, with chain Y = special connec- tion head (to be specified in writing)	0 = without A ³⁾ = programmable transmitter 2-wire (5334D) B ³⁾ = transmitter with HART [®] protocol 2-wire (5337D) C ³⁾ = transmitter PROFIBUS [®] / Fieldbus(5350B)	0 = without Y = acc. description
	28 = 285		2 = 2x type J, cl 2; 1.4404				
	34 = 345		3 = 1x type K, cl 2; Alloy 600				
	XX ¹⁾ = special length		4 = 2x type K, cl 2; Alloy 600				
			5 = 1x type J, cl 1; 1.4404				
			6 = 2x type J, cl 1; 1.4404				
			7 = 1x type K, cl 1; Alloy 600				
			8 = 2x type K, cl 1; Alloy 600				
			X ²⁾ = special				

¹⁾ Please specify special length in writing ²⁾ Please specify special type in writing ³⁾ Please specify measuring range in writing



Insertion thermocouple, protection Exia,
 ½" NPT M union and nipple

Model ¹⁾	Immersion length [mm]	Process connection	Sensor type/ category	Wiring	Connection head	Head transmitter	Options
TTL-WD	XX ²⁾ = special length	8 = ½" NPT M	1 = 1x type J, cl 2; 1.4404 2 = 2x type J, cl 2; 1.4404 3 = 1x type K, cl 2; Alloy 600 4 = 2x type K, cl 2; Alloy 600 5 = 1x type J, cl 1; 1.4404 6 = 2x type J, cl 1; 1.4404 7 = 1x type K, cl 1; Alloy 600 8 = 2x type K, cl 1; Alloy 600 X ³⁾ = special	2 = 2-wire	G = form B, with chain X = special connection head (to be specified in writing)	0 = without A ⁴⁾ = programmable transmitter 2-wire (5334D) B ⁴⁾ = transmitter with HART® protocol 2-wire (5337D) C ⁴⁾ = transmitter PROFIBUS®/Fieldbus (5350B)	0 = without Y = acc. description

¹⁾ Thermocouples TTL-WD can be combined with a large number of thermowell designs. Operation without thermowell is not allowed.

²⁾ Please specify special length in writing

³⁾ Please specify special type in writing

⁴⁾ Please specify measuring range in writing



Spare measuring insert for thermocouple thermometer according to DIN 43772 and protection Exia

Model	Immersion length [mm]	For form	Measuring insert length	Sensor type/ category	Wiring	Head transmitter	Options
TTL-M82 Ø8 mm	0050 = 500 0071 = 710 001T = 1000 00T4 = 1400 002T = 2000 XXXX ¹⁾ = special length	1	537 747 1037 1437 2037 acc. to special length	1 = 1x type J, cl 2; 1.4404 2 = 2x type J, cl 2; 1.4404 3 = 1x type K, cl 2; Alloy 600 4 = 2x type K, cl 2; Alloy 600 5 = 1x type J, cl 1; 1.4404 6 = 2x type J, cl 1; 1.4404 7 = 1x type K, cl 1; Alloy 600 8 = 2x type K, cl 1; Alloy 600 X²⁾ = special	2 = 2-wire	0 = without A³⁾ = programmable transmitter 2-wire (5334D) B³⁾ = transmitter with HART [®] protocol 2-wire (5337D) C³⁾ = transmitter PROFIBUS [®] /Fieldbus (5350B)	0 = without Y = acc. description
	TTL-M62 Ø6 mm	0010 = 100 0016 = 160 0025 = 250 0040 = 400 XXXX ¹⁾ = special length	2G (Model TTL-CB4 only)				
TTL-M52 Ø5 mm	0010 = 100 0016 = 160 0025 = 250 0040 = 400 XXXX ¹⁾ = special length	2G (Model TTL-B94 only)	267 327 417 567 acc. to special length				
	0022 = 225 0028 = 285 0034 = 345 XXXX ¹⁾ = special length	3F	327 387 447 acc. to special length				
	0016 = 160 0025 = 250 0028 = 280 XXXX ¹⁾ = special length	3G	267 417 447 acc. to special length				
	1406 = 65/140 2412 = 125/200 4406 = 65/200 5412 = 125/260 1906 = 65/140 2912 = 125/200 4906 = 65/200 5912 = 125/260 XXXX ¹⁾ = special length	4	322 382 382 442 322 382 382 442 acc. to special length				

¹⁾ Please specify special length in writing

²⁾ Please specify special type in writing

³⁾ Please specify measuring range in writing



Screw-in thermocouple with cable, protection Exia,
protective tube male according to DIN 43772, p_{max} 10 bar

Model	Immersion length "EL" [mm]	Process connection	Sensor type/ category	Wiring	Cable "CL"	Head transmitter	Options
TTL-SN	10 = 100 Ø6 16 = 160 Ø6 25 = 250 Ø6 40 = 400 Ø6 XX¹⁾ = special length Ø6	2 = G ½	1 = 1x type J, cl 2; 1.4404 2 = 2x type J, cl 2; 1.4404 3 = 1x type K, cl 2; Alloy 600 4 = 2x type K, cl 2; Alloy 600 5 = 1x type J, cl 1; 1.4404 6 = 2x type J, cl 1; 1.4404 7 = 1x type K, cl 1; Alloy 600 8 = 2x type K, cl 1; Alloy 600 X²⁾ = special	2 = 2-wire	S = silicone cable P = PTFE cable X³⁾ = special length and/or material	0 = without	0 = without Y = acc. description

¹⁾ Please specify special length in writing

²⁾ Please specify special type in writing

³⁾ Please specify special length and/or material cable "CL" (standard model 1000 mm) in writing

Insertion thermocouple with cable, protection Exia

Model	Immersion length "EL" [mm]	Process connection	Sensor type/ category	Wiring	Cable "CL"	Head transmitter	Options
TTL-SA	10 = 100 Ø6 16 = 160 Ø6 25 = 250 Ø6 40 = 400 Ø6 XX¹⁾ = special length Ø6	0 = without	1 = 1x type J, cl 2; 1.4404 2 = 2x type J, cl 2; 1.4404 3 = 1x type K, cl 2; Alloy 600 4 = 2x type K, cl 2; Alloy 600 5 = 1x type J, cl 1; 1.4404 6 = 2x type J, cl 1; 1.4404 7 = 1x type K, cl 1; Alloy 600 8 = 2x type K, cl 1; Alloy 600 X²⁾ = special	2 = 2-wire	S = silicone P = PTFE X³⁾ = special length and/or material	0 = without	0 = without Y = acc. description

¹⁾ Please specify special length in writing

²⁾ Please specify special type in writing

³⁾ Please specify special length and/or material cable "CL"(standard model 1000 mm) in writing



Technical data special materials of protective tube

(Others on request)

Alloy 600 (Material no. 2.4816)	Max. temperature 1090°C. Excellent corrosion resistance against oxidation up to 980°C, to carburization and to stress corrosion cracking at elevated temperatures.
Alloy 601 (Material no. 2.4851)	Max. temperature 850°C. Excellent resistance against oxidation, against carburization and good mechanical properties.
Alloy 625 (Material no. 2.4856)	Max. temperature 815°C. Excellent corrosion resistance against oxidation of sulphuric, nitric, phosphoric, hydrochloric acid and alkalis. It is widely used in a variety of high temperature aerospace, chemical process industry, and power industry applications. It provides excellent service in short term applications at temperatures up to approximately 815°C long-term elevated temperature service, use of alloy 625 is best restricted to a maximum of 595°C.
Alloy 800 (Material no. 1.4876)	Max. temperature 870°C. Good resistance to oxidizing agents, fuels nitriding and maintaining good mechanical properties from cryogenic to high temperature environments for high temperatures should go to 800H.
Alloy 800H (Material no. 1.4958)	Max. temperature 1100°C. basic composition as alloy 800 but with higher creep and rupture.
Alloy 800HT (Material no. 1.4959)	Max. temperature 1100°C. High creep and stress rupture resistance above 700°C. It is used specially at temperatures above 800°C.
Alloy DS (Material no. 1.4862)	Max. temperature 1100°C. High creep and stress rupture resistance above 700°C. It is specially used at temperatures above 800°C.
1.4845 (AISI 310 S) (Material no. 1.4845)	Max. temperature 1150°C. Excellent high temperature properties with good ductility and weldability. It resists oxidation in continuous service at temperatures up to 1150°C. Excellent resistance at normal temperatures, and when in high temperature service exhibits good resistance to oxidizing and carburizing atmospheres. Resists fuming nitric acid at room temperature and fused nitrates up to 425°C. Good resistance to oxidation in intermittent service in air at temperatures up to 1040°C and 1150°C in continuous service. Good resistance to continuous heat at 1150°C. Good resistance to thermal fatigue and cyclic heating. Widely used where sulphur dioxide gas is encountered at elevated temperatures. Continuous use in 425...860°C range not recommended due to carbide precipitation.
Alloy 200 (Material no. 2.4066)	Max. temperature 300°C. Excellent corrosion resistance against many corrosive media (specially to caustic alkalis, halides and a large number of organic compounds).
Alloy 201 (Material no. 2.4068)	Max. temperature 600°C. Equal Alloy 200 but with a very low carbon content.

Dimensions [mm]

TTL-B...

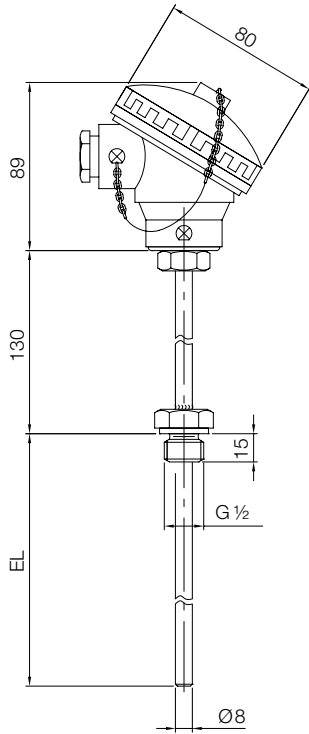

TTL-C...

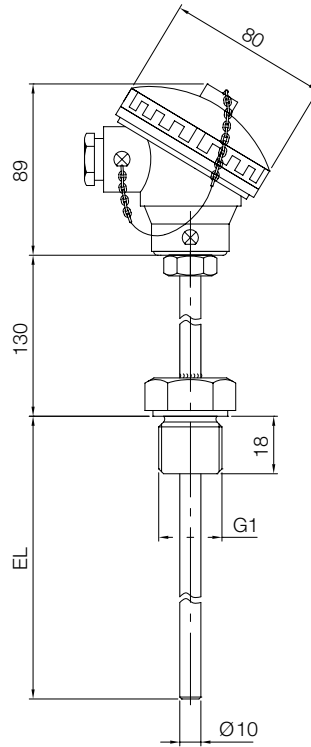

TTL-G...

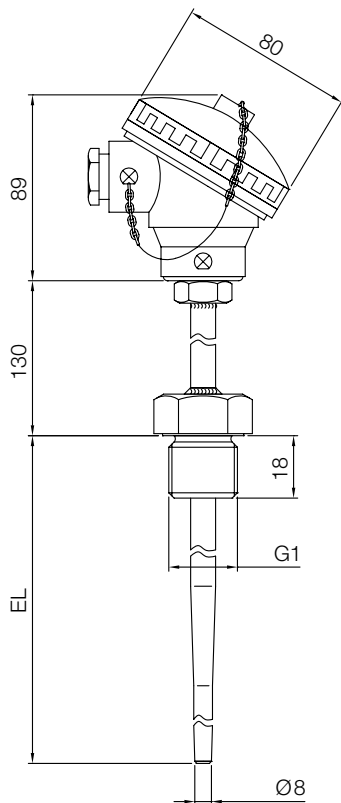

TTL-1F...

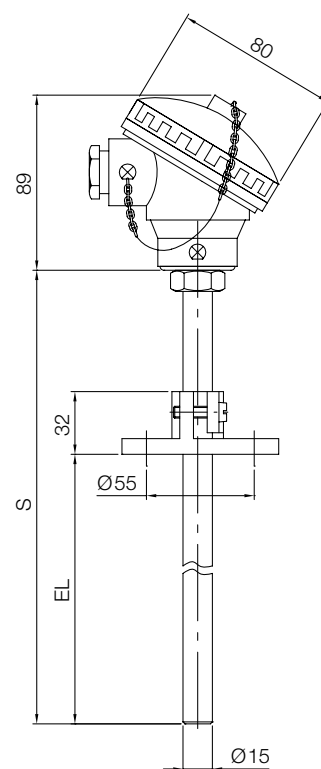

TTL-D...

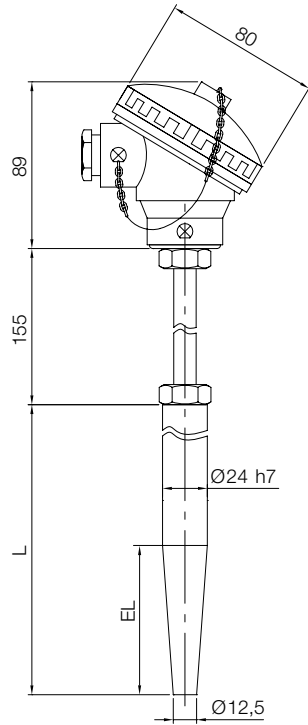

L = overall length
weld-on probe
EL = immersion length

TTL-F...

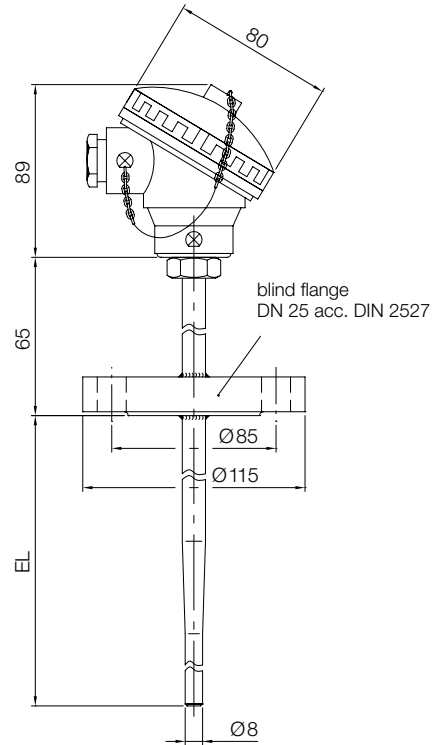

TTL-WD

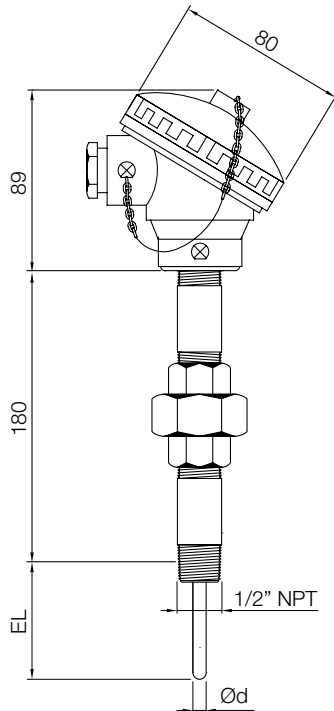

TTL-M

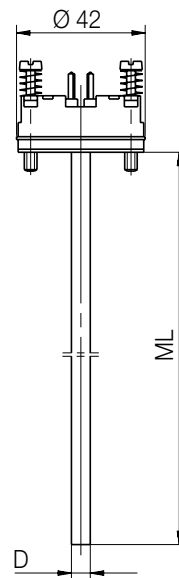

Diameter D	
... M82...	8 mm
... M62...	6 mm
... M52...	5 mm

ML = length measuring insert

TTL-SA...

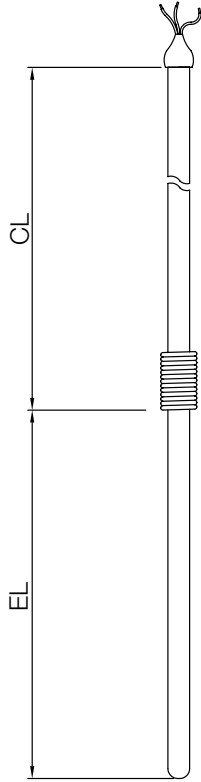

TTL-SN...

